



The Middelgrunden Offshore Wind Farm

A Popular
Initiative

Middelgrunden Offshore Wind Farm



Number of turbines.....	20 x 2 MW
Installed Power.....	40 MW
Hub height.....	64 metres
Rotor diameter.....	76 metres
Total height.....	102 metres
Foundation depth.....	4 to 8 metres
Foundation weight (dry).....	1,800 tonnes
Wind speed at 50-m height...	7.2 m/s
Expected production.....	100 GWh/y
Production 2002.....	100 GWh (wind 97% of normal)
Park efficiency.....	93%
Construction year.....	2000
Investment.....	48 mill. EUR

Kastrup
Airport

The Middelgrunden Wind Farm is situated a few kilometres away from the centre of Copenhagen. The offshore turbines are connected by cable to the transformer at the Amager power plant 3.5 km away.

Kongedybet

Hollænderdybet

Middelgrunden

Saltholm Flak

From Idea to Reality



The idea of the Middelgrunden wind project was born in a group of visionary people in Copenhagen already in 1993. However it took seven years and a lot of work before the first cooperatively owned offshore wind farm became a reality. Today the 40 MW wind farm with twenty modern 2 MW wind turbines developed by the Middelgrunden Wind Turbine Cooperative and Copenhagen Energy Wind is producing electricity for more than 40,000 households in Copenhagen.

In 1996 the local association Copenhagen Environment and Energy Office took the initiative of forming a working group for placing turbines on the Middelgrunden shoal and a proposal with 27 turbines was presented to the public.

At that time the Danish Energy Authority had mapped the Middelgrunden shoal as a potential site for wind development, but it was not given high priority by the civil servants and the power utility. Nevertheless the Parliament supported the idea and made funding available for further investigations. These developments together with strong public support from 1000 members of the newly established cooperative and cooperation with the local utility cleared the road for the project.

From 1997 to 1999 two visualizations and an Environmental Impact Assessment Study were carried out and a large public debate took place in connection to the public hearings. Following the first public hearing the original proposal of 27 turbines in three rows was changed. Instead it was decided to place 20 turbines in a slightly curved line. The public grant also covered an analysis of the organizational and economic aspects of the cooperatively owned part of the project, since the cooperative did not possess any financial means at these early planning stages.

A comprehensive information work took place, in relation to relevant authorities, NGOs and many future shareholders of the cooperative. During the process we were in contact with 50-100,000 people. 10,000 local people pre-subscribed for shares. This proved strong local support and helped in the approval phase. In December 1999 the final approval was given and finally during 2000 the wind farm rose from the sea.

Private people have been a driving force in this project, like in the successful development of Denmark as a leading nation in wind technology. The working group, the management of the cooperative, Copenhagen Energy and the former Mayor of Environment Bo A. Kjeldgaard made huge efforts to bring the project to a success.

With this booklet we want to lend a helping hand to other people who wish to play a role in the development of sustainable energy.

*Copenhagen Environment and Energy Office
The Middelgrunden Wind Turbine Cooperative*

Making Wind Popular



1600 people visited the construction site during a visitors-day in May 2000. During the construction process the cooperative paid large attention to involving the members and the public.

After several attempts in other parts of Denmark, the Middelgrunden Wind Turbine Cooperative became the first offshore wind project based on sale of shares. The utilities had their first experiences with offshore wind developments from the Vindeby project in 1991 and the Tunø project in 1995. In 2002 the utilities established an offshore wind farm at Horns Rev in the North Sea and the Nysted Offshore Wind Farm will be built at Rød-sand in 2003. A local cooperative has installed ten turbines close to the island Samsø in 2002.

Ownership

Private people have played an important role in the development of Denmark into a strong wind nation from the very beginning and till today, when 14.4% of the Danish electricity consumption is provided by the wind.

More than 150,000 Danish families are members of wind turbine cooperatives. Private investors have installed 86% of all Danish wind turbines. Until recently, the cooperatives were a very important and dominant factor in the development of the Danish wind energy sector. Lately, single person ownership has by far superseded the importance of the cooperatives.

In the coming years the utilities are expected to play an increasing role in the establishment of large-scale offshore wind farms, though the Danish pilot programme, which demanded the utilities to establish 750 MW offshore capacity before 2008, has been cancelled by the new government. Only the first two projects mentioned above will be completed as demonstration projects. A call for tender is being prepared for the other three projects.

Local acceptance is necessary

Public resistance against wind turbines in the landscape is and has been one of the largest barriers to the development of wind power – and thus to the development of an environment-friendly and sustainable energy supply. This counts both for Denmark and other countries.

Earlier Danish legislation secured local participation in all private wind developments. At the moment, there is a wide support for wind energy in Denmark. Opinion polls show that more than 70% of the population are in favour of wind power and only about 5% are against.

In 2000 the limits to ownership were removed. The result may easily be a decrease in public support to wind power. Turbines owned by strangers are not accepted locally.

Danish wind power capacity and share of electricity consumption

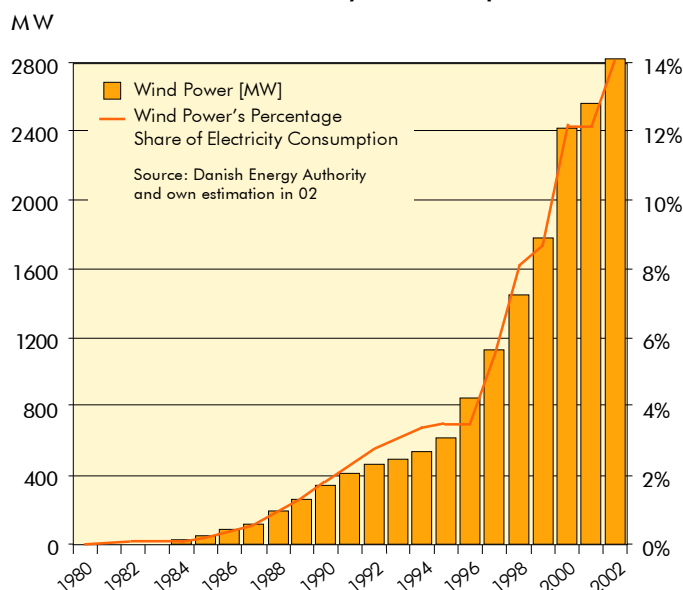

"I bathe all year at Helgoland and enjoy the view of the turbines. It gives positive energy."
Marianne Iversen.

Helgoland is a public bath at Amager Beach. The distance to the nearest turbine at Middelgrunden is 2 km.

Danish offshore wind developments.



"Whenever the wind turbines at Middelgrunden are running, I know the wind outside Skejvshoved Marina is perfect for sailing and training with the team."

Jeppe Blak-Nielsen, yachtsman.

Location	Power	Installation
1 Vindeby	5 MW	1991
2 Tunø Knob	5 MW	1995
3 Middelgrund	40 MW	2001
4 Horns Rev	160 MW	2002
5 Samsø	22 MW	2002
6 Rødsand	160 MW	2003

Cooperatives are better accepted

The Middelgrunden Cooperative and Copenhagen Energy and Environment Office put an enormous amount of energy and time into securing local acceptance already at an early stage of the project. Different interest groups were contacted and involved in the discussions about the project before all the investigations and detailed planning even started.

As an example The Danish Society for the Conservation of Nature at first decided to reject the proposed location, but the local committee was in favour of the project. Many local members approached the mass media and opposed the decision of the national board that had to revise its decision at the end. At the final hearing there were many expressions of support and only few remained in opposition.

During and after the construction there was surprisingly little resistance to the project, considering the visual impact from the large turbines, located just 2 km away from e.g. a very popular beach near Copenhagen. The reason for this lack of protest is believed to be the strong public involvement in the planning phase and as investors.

The experience from two later private offshore projects also shows that public involvement in the planning phase and co-ownership improve the acceptance. The Samsø project, which is developed by a cooperative with local people and municipalities as members, was finished early 2003. The other project near Grenå, owned by a private developer, has been significantly postponed due to local resistance.



Ownership - new installed wind capacity

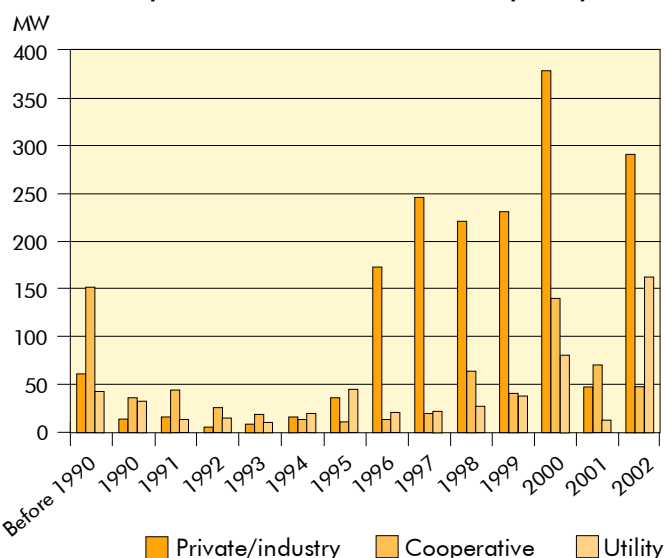

Development in ownership of wind farms in Denmark. MW installed power each year. The 2002 data are preliminary.

Ownership - total wind capacity 2002

The total installed capacity is 3000 MW by the end of 2002. The total number of turbines is 5600.

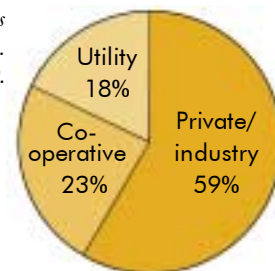

During 2002 the second cooperatively owned offshore wind farm was installed near Samsø. The wind farm is part of the Samsø Renewable Energy Island project.

9 Good Reasons for Local Ownership

Local commitment to the Middelgrunden project has proven a key factor in carrying through this wind development. Without the involvement of local people the Middelgrunden project would have never succeeded. There are many good reasons for and advantages of local ownership.

1. Local ownership results in more installed wind capacity

In countries with a legal and financial environment that enables local wind developments, local investment has played a major role. In Denmark 86% of all turbines are owned by private, local investors and most early projects were local.

2. Local ownership creates local dialogue and acceptance

Through dialogues with different interest groups, Copenhagen Energy and Environment Office and the Middelgrunden Cooperative, with its 8,500 members, generated a widespread understanding for and social acceptance of the chosen location and layout of the farm. The Danish experience shows that there are more complaints when utilities install wind than when the local population does so.

3. Local ownership raises public awareness

During the establishment of the Middelgrunden project more than 50,000 people received information directly and more than 50,000 people visited the Middelgrunden homepage. For many people electricity suddenly was something that did not just come out of the socket.

4. Local ownership solves problems and conflicts

The Middelgrunden working group avoided or solved potential conflicts by taking direct contact to various local interest groups at an early stage in the development of the project. Contact was taken to The Middelgrunden Fort, The Association for Beautification of the Capital, and local fishermen. Also the contact to and involvement of the local branch of The Danish Society for the Conservation of Nature was important.

5. Private investment promotes cheaper and better technologies

A private wind cooperative often pays more attention to the details of the wind project than the utilities do, since the wind development is only a small part of their business. In the Middelgrunden project this resulted in a cheaper solution for the grid connection than the one originally proposed by Copenhagen Energy.

6. Local production demands less transmission lines and saves electricity

The grid loss is minimised by local electricity production. In Denmark the average grid loss is 9% of the electricity production, in some countries it goes as high as 17%. The loss inside the Middelgrunden wind farm is measured at 2.7%, including the cable to the shore and distribution the loss is less than 5%.

7. Local turbines are democratic

With local investment in power production, it is the local people, who take the decision on planning and implementation of power supply. It brings more responsibility to the local level, which is subject to both benefits and disadvantages.

8. Local production makes sustainable development understandable

The Middelgrunden project is a local and clear example on how people can contribute to a sustainable development. The wind turbines on Middelgrunden illustrate our use of resources and enable us to see the consequences of their use.

9. Local ownership gives people opportunity to act for sustainable development

The Middelgrunden project has been an outstanding possibility of engaging the entire population of the capital in a practical and sustainable action. Seen in the context of Agenda-21 and the plan of action of the UN environmental summit in Rio such initiatives are highly important.

The Middelgrunden Cooperative



Annual Assembly. 400 shareholders show up at the general meetings. Especially during the planning and construction phase the shareholders followed the development closely.

The Middelgrunden Wind Turbine Cooperative was founded in May 1997 with the aim to produce electricity through the establishment and management of wind turbines on the Middelgrunden shoal.

Preceding the cooperative, a working group was organised in 1996 by the Copenhagen Environment and Energy Office (CEEEO). The working group consisted primarily of local people interested in wind energy and who believed that the project was going to be a success.

The management

The management consists of seven people, who came out of the working group. The commitment and different professional backgrounds of the managers and their collaboration with various consultants behind the project, have secured success to the project.

The management has hired CEEEO as technical advisor, administrator and secretariat. During the planning and construction period the working group, the management and many other people put in a lot of voluntary work to make the project happen.

Partnership

The wind turbine cooperative is established as a partnership. One share corresponds to 1/40,500 of the partnership. A partnership has joint and several liability and it is the common model of ownership for Danish wind turbine cooperatives.

The Middelgrunden Wind Turbine Cooperative has minimised the risk of joint and several liability by not being able to contract debt in the partnership. This is ensured in the Bylaws, which maintain that the partnership cannot contract debt, and that the turbines must be adequately insured.

Who are the shareholders?

8.552 electricity consumers are co-owners of the wind farm, which makes the project outstanding. Most shareholders are people living in Greater Copenhagen, but also some companies, organisations, unions and foundations saw the importance of participating in a highly visible and visionary project. E.g. the local chapters of The Danish Union of Teachers and The General Workers Union have bought shares to cover the electricity consumption in their own buildings.

Number of shares per shareholder

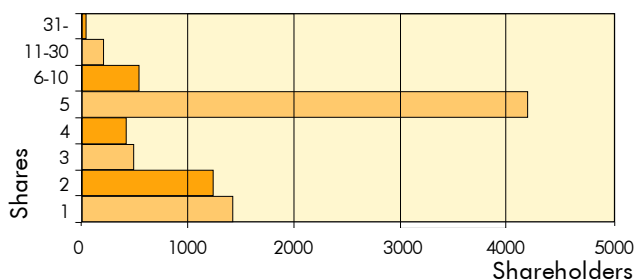

Many private shareholders own 5 shares, which is the optimum number under current Danish tax regulations.

*Geographical distribution of shares
Nearly 90% of the shares are owned by people or companies from Greater Copenhagen.*

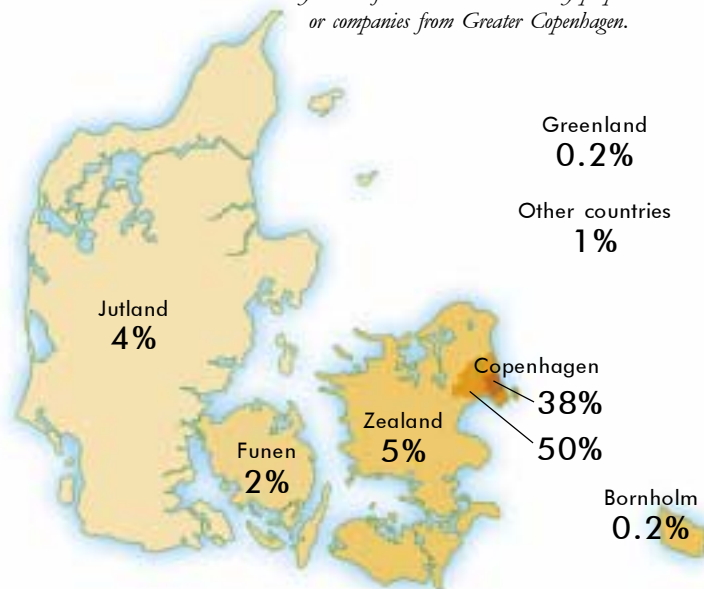

With the many involved and committed members the cooperative has fulfilled its most important aim: to show public involvement in environment projects of high calibre. In appreciation of the public involvement, the project has received several prizes, including The European Solar Prize and The Global Energy Award in 2000.

Erik Christiansen, chairman of the Cooperative

In the beginning only people living or working in Copenhagen or the neighbouring municipalities were allowed to buy shares. In 2000 new regulation came into force and people from all Denmark could buy shares, as long as they had reached full legal age, which is 18 in Denmark. People from outside Denmark can also buy shares under certain conditions. Still close to 90% of all shares are owned by local people and organisations.

Ownership and Organisation



Several thousands of people participated in the official opening of the Middelgrunden Offshore Wind Farm in May 2001. The day was organised and celebrated together by the two owners.

The utility

Copenhagen Energy Wind is a part of Copenhagen Energy, which is owned by the Municipality of Copenhagen. Copenhagen Energy has recently merged with SK-Energy and is now one of the largest energy producers in the eastern part of Denmark.

In 1996 Copenhagen Energy took the first step to investigate the feasibility of an offshore wind farm at Middelgrunden. After two years of negotiations and overcoming political differences, a contract between the cooperative and the utility was signed.

SEAS Wind Energy Centre acted as consultant for the local utility and headed the project organization for the establishment of the wind farm.

The Middelgrunden Wind Farm is the world largest wind farm based on joint ownership by a cooperative and a utility. The model builds on positive experiences from the onshore wind developments at Avedøre Holme and Lynetten, which were established in 1993 and 1996 in collaboration between local cooperatives and the utility.

The whole project has been developed in cooperation between Middelgrunden Wind Turbine Cooperative and the local utility Copenhagen Energy. All contracts were drawn up jointly during planning and construction, and all investment costs were shared between the two developers. During the construction and testing period income from electricity sale as well as the costs were equally shared between the two developers, thus avoiding conflicting interests on what wind turbines to finish first.

After final delivery the two owners run as separate businesses. The cooperative owns and manages the 10 southern turbines and the 10 northern turbines are owned by the utility. But still the two owners collaborate on the operations.

The strength of cooperation

The cooperation between the Middelgrunden Wind Turbine Cooperative and Copenhagen Energy has clearly strengthened the project and both parties have gained from the arrangement. Copenhagen Energy and SEAS possess the big knowledge about technique, contractor work, etc. The wind cooperative has the knowledge from the private wind sector, enthusiasm and commitment as well as better contacts with the public and the press.

The locally based commitment, along with cooperation between the cooperative, the local utilities, and the municipality of Copenhagen, constituted a significant precondition for the development of the project. This cooperation has provided credibility to the project in relation to politicians and the public.



"In my opinion the success of this project can be explained especially by the constructive cooperation between the municipality, the municipal energy company and the private partnership. The cooperation ensured the local commitment and engaged local authorities and politicians."

Winnie Berndtson, Mayor of Environment, Copenhagen.



Strengths of cooperation

	The Cooperative	Copenhagen Energy
Strengths	<ul style="list-style-type: none"> Active and committed members Political contacts Active dialogue with all stakeholders (authorities, organisations, fishermen, etc.) Active involvement of the media Direct dialogue with the authorities Large public support 	<ul style="list-style-type: none"> Denmark's largest municipal-owned power utility Good and direct contact to the municipality Technical back-up organisation Wind technology expertise of SEAS Wind Energy Centre Easily available financing resources Trustworthy partner
Weaknesses	Financially weak starting point	Power utility demand on grid connection (technically and economically –nearly prohibitive)

Organisation - planning and construction phase

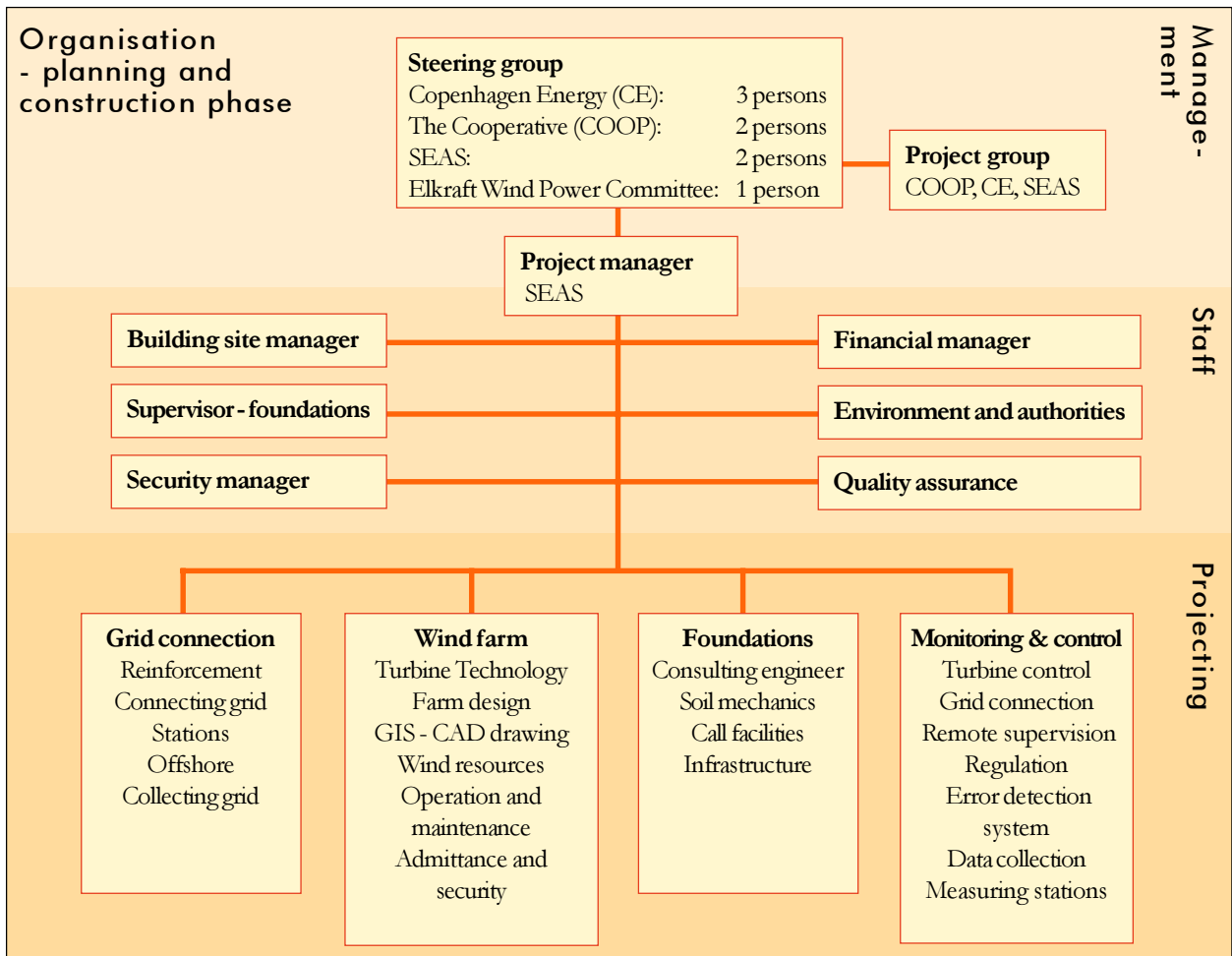

Organisation - operation

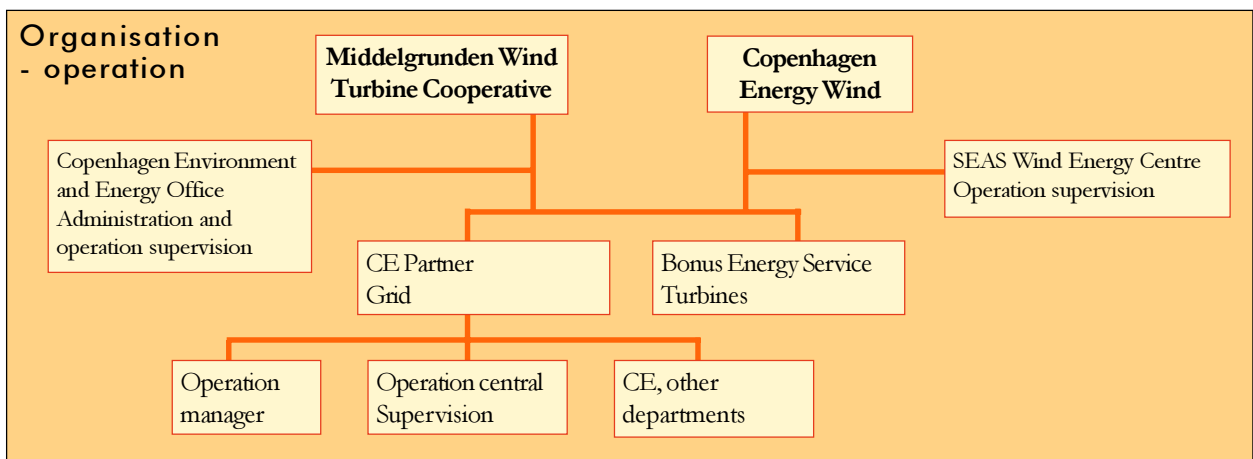

Sep

Oct

Nov

Dec

Jan

Feb

Mar

April

May

Jun

Jul

Aug

Sep

Oct

Nov

Dec

Jan

Feb

Mar

April

Application on principal approval

Application on principal approval with CE

First public hearing (27 turbines)

The Planning Process



The restructuring of the Danish electricity sector and the introduction of a new regulatory mechanism governing the wholesale price of renewable energy resulted in a very narrow timetable for the decisions connected to the Middelgrunden project. This situation considerably influenced both the planning process and the construction work.



Visualization versus reality. The visualization at the top was made for the 2nd hearing. The computer manipulation is quite close to reality.

Long process

Due to the new regulations the contracts with the turbine manufacturer and the foundations and grid contractors had to be signed before the end of 1999, to allow optimal grants from the Renewable Energy Scheme. To achieve this was not an easy task. The project had to pass three public hearings, before it finally received the approval from

the Danish Energy Authority on December 13, 1999. Already eight days later the contracts were signed due to the large flexibility and cooperation from all partners involved in the project.

The short planning time resulted in extra costs and special precautions not necessary for future projects, but still the project exceeded the budget only by 5%.

Visualization of the Middelgrunden Wind Farm seen from the beach of Amager. At this page the first proposal with 27 turbines in three rows at facing page the chosen solution, 20 turbines in a curved line.



Public funding

The Danish Energy Authority granted 680,000 EUR for preliminary investigations of technical and environmental aspects of offshore wind power on the Middelgrunden site, including the Environmental Impact Assessment Study. Furthermore, the grant covered an analysis of the organizational and economic aspects of the cooperatively owned part of the project.

The support was granted because the project covered new ground both technically and organisationally. Future wind developments have gained from the experiences at Middelgrunden.

First public hearing – 27 turbines

First the project had to pass a public hearing in 1997. The authorities received 24 positive and 8 negative responses. The authorities themselves also raised a number of questions that were answered during the publicly funded pre-investigations. Because of resistance from authorities and interest groups, especially regarding the visual impact of the project, the size of the farm had to be downgraded from the originally proposed 27 turbines placed in three rows, to 20 turbines.

At this stage some locals were worried about potential noise impact from the farm, but after a demonstration tour to a modern onshore wind turbine, they were convinced that there would be no noise impact from the Middelgrunden turbines. Consequently, the southern part of the shoal, which is closest to the coast and inhabited area, could be used for the wind farm as well.

Second public hearing – 20 turbines

The new proposal consisted of 20 turbines placed in a slightly curved line chosen in accordance with the historically developed Copenhagen defence system around the City. The technological development of wind turbines meant that the reduction in the number of turbines could be fully compensated by using larger turbines. The changes could therefore be implemented without

May	Jun	Jul	Aug	Sep	Oct	Nov	Dec	Jan	Feb	Mar	April	May	Jun	Jul	Aug	Sep	Oct	Nov	Dec
				Second public hearing (20 turbines)								Principal approval							
															Third public hearing (EIA)				
																			Final permission

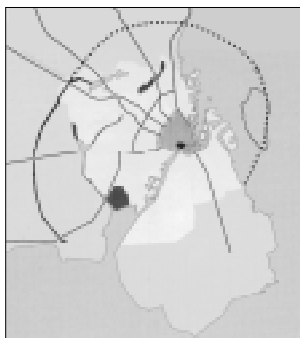
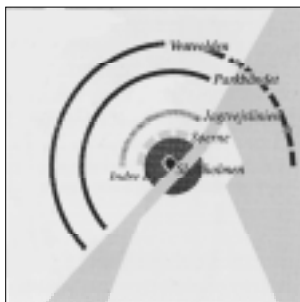

The curve of wind turbines at Middelgrunden continues Copenhagen's structure, which has the shape of a super-ellipse represented by Vestvolden (old defense system west of Copenhagen), Parkbuen and Ring Road 2.

decreasing the installed power of the wind farm.

The project was subjected to a new mandatory hearing, focusing on the visual impact. In-depth analysis was undertaken in order to visualize the impact of 20 turbines. This was important due to the controversial site selected for the project. Furthermore, the visualizations were widely used as comprehensive illustrations during the public hearing and several reports and brochures about the visual impact were published. The second hearing was passed in September 1998.

Final hearing

The last step was a public hearing based on the careful environmental impact assessment carried out during the summer of 1999. In accordance with the ESPOO Convention, hearings were held in Denmark as well as in Sweden and the results have been published in several reports.

At the final hearing a large number of local groups and committees, not mentioning the several thousands of shareholders, recommended and supported the project. Only a relatively small group of yachtsmen, fishermen, individuals and politicians remained in opposition.



"As a fisherman I am not in favour of offshore wind turbines, but we have had to accept the wind farm on the Middelgrunden Shoal."

Torben Christensen
Osterbro Fishing Association



Environmental Impact Assessment

A series of analyses was carried out to examine various impacts of the project. The Environmental Impact Assessment (EIA) consultants analysed:

- Visual impact (visualization, 2nd hearing)
- The risk of leaking debris and heavy metal contamination from the former dump site
- Noise propagation
- Influence on the free flow of water in the Sound (Øresund)
- Risk of collisions with vessels
- Impact on flora and fauna
- Risk of finding shipwrecks and deposits from the Stone Age of archaeological interest
- Saved fuel and avoided pollution
- Alternative project locations

Visual impact

The visual impact studies of the proposed project were done for 11 locations along the Danish and Swedish coasts and at sea.

Heavy metal contamination

Middelgrunden was used for dumping harbour sludge and other material for 200 years. The investigations showed that 3-4 turbine sites were contaminated by heavy metals (mercury and copper). The chosen project with the arch made it possible to avoid some contaminated areas, and the problems with heavy metals were less than in the original proposal.

Computer simulations were carried out in order to optimise the working condition regarding dispersion of sediment to the sea. The most environment-friendly method is to treat the sediment as little as possible during the dredging work. The preparation for foundations and sea-cables was carried out as careful as possible to avoid dispersion of the sediment. Copenhagen Environmental Protection Agency regularly controlled the work.

Noise propagation.

Noise propagation was calculated, but it is not supposed to cause any problems, as the distance to populated areas is more than 2 km.

Water flow in the Sound

The establishment of the wind farm will only reduce the water flow in the sound between Denmark and Sweden by 0.0012%. It was necessary to investigate this matter, as the change in flow could influence the breeding of codfish in the Baltic Sea. In order to compensate the decrease of water flow in the Sound caused by the foundations, it was discussed to remove some 4,000 m³ of deposits from an optimal place on the ocean floor. The accuracy of the theoretically calculation of the reduction of the water flow did not justify compensation treatment.

Eelgrass is re-establishing itself at the site

Avoided pollution during an average wind year

Sulphur dioxide.....	150 tonnes
Nitrogen oxides.....	140 tonnes
Carbon dioxide.....	81,000 tonnes
Dust and clinker.....	5,200 tonnes

Risk of collisions

The turbines are placed on shallow water, so the placement of the wind farm is likely to reduce the number of vessels running aground, which used to happen once a year, as the radar signal from the turbines clearly indicates the shoal. The risk of collision with a turbine is estimated at 8% per year, but the chance of a turbine overturning is insignificant.

Flora and fauna

Flora and fauna was mainly influenced during the construction period. In order to determine the level of influence video inspection was performed before the upstart. Inspection by biologists right after finalizing the construction showed that the eelgrass was unaffected on sites next to the places where dredging took place. The last inspection will take place 3 years after the establishment of the wind farm, and it is expected that the eelgrass will be totally re-established in the area by then.

There are no sensitive bird species in the area, and the existing ones, like swans, ducks, eiders and gulls are expected to use the area as before.

Fishing

Intensive netting takes place in the area, primarily for eel, cod and flatfish. Compensation was settled with the local fishermen, as fishing was prohibited during construction.

Now fishing can resume as before, but no tools scraping the bottom may be used and it is prohibited to anchor within 200 metres from the sea-cable. In the future the foundations are likely to serve as a reef and create a habitat for bottom animals and thus food for more fish in the area.



Lessons Learned

Recommendations for wind cooperatives on planning and organisation of large wind projects

- 1 People – potential shareholders, neighbours, interest groups, politicians etc. – must be involved in the relevant parts of the project during the whole process.
- 2 Problems with acceptance can be avoided, if interest groups and authorities are contacted at an early stage.
- 3 It is essential to disseminate the appropriate information at the right time. Many initial reservations towards the Middelgrunden project were based on the fear of negative impact. Careful information distribution and dialogue assured that the reservations did not develop into serious problems for the project. E.g. the neighbours were invited on a tour to visit a modern wind turbine, which convinced them that noise would not be a problem.
- 4 Relevant and critical reactions should be taken seriously and it is also necessary to adapt the project in order to meet concerns. In the Middelgrunden project the design of the wind farm was changed. It cost an extra year of planning, but broad local support was assured in the end.
- 5 The Environmental Impact Assessment should be taken very seriously, and responses in the hearing have to be taken into account.
- 6 Large project needs a minimum amount of start up capital – or requires a large amount of voluntary work.
- 7 Be very careful when submitting the tender and writing up the contracts. The contractors, who constructed the foundations, claimed extra costs (see page 22).

Technical recommendations for new offshore wind farms

- 1 The turbine tender has to be conducted before the foundation in order to avoid changes in the detailing if possible.
- 2 Special development is needed for placing and compaction of the rock cushion.
- 3 All operations have to be tested in advance - also the ones looking simple, as all operations of the standard type onshore are complicated offshore.
- 4 Carry out as many operations onshore as possible.
- 5 Transport of people to the turbines offshore has to be organized very carefully.
- 6 Logistic planning is a must for keeping the time schedule.
- 7 Onshore 690 V experience cannot be transferred to cables at 30 kV, as special safety is required.
- 8 Successive starting up of the production seems easy, but gives problems of many kinds.
- 9 Moist in the turbine tower was higher than expected before turbines came into operation.

April	May	Jun	Jul	Aug	Sep	Oct	Nov
Casting concrete for foundations				Placement of foundations including lower section of tower			

Foundations



One very important technical issue has been to develop the most appropriate foundations. Concrete gravity foundations proved to be the most cost-effective solution and were chosen. Through optimisation it was possible to gain substantial savings. The type and size of the turbine itself influenced the design of the support structure and construction method. The parallel decision process caused by the tight timetable resulted in extra costs, e.g. for extra mould for concrete casting.

As part of the pre-investigations, the independent consultant engineers Carl Bro and NIRAS initially analysed two types of foundations: a standard steel or concrete gravity caisson foundation used for wind turbines on land, and a monopile solution. To find the most cost-effective solution the international tender included both concrete and steel design of the gravity foundations. Possibilities were left open to bids based on alternative solutions, e.g. a monopile.

Casting of foundations in an old dry dock in the former B&W Shipyard. The dry dock could exactly hold 20 foundations. The shape of the ice cone is inspired from the hull of a ship and popularly known as 'the Tulip'.



Price comparison	
Gravity foundations, concrete....	315,000 EUR each
Gravity foundations, steel.....	380,000 EUR each
Monopile.....	420,000 EUR each
Prices for different types of foundations based on the tender result	

Evaluation of alternatives

During the evaluation of the bids for the foundations, it was concluded that the monopile was not feasible for the actual site, due to the presence of a special type of limestone. The shallow water and the relatively protected sea with little waves and current favoured a gravity type foundation.

The steel caisson type cannot compete in shallow water with concrete even with very low prices of steelwork. At a larger water depth (>10 m) other types of steel foundation can be more competitive than the standard gravity solution according to the bidders and other investigations.

For wind farms with a larger number of turbines and located in shallow waters (<10 metres depth) rationalization can be expected especially with respect to the placement of the foundation, but concrete will probably still be the cheapest solution.



The switchgear and transformer was placed on top of the concrete foundation just before placement of the lower part of the tower.



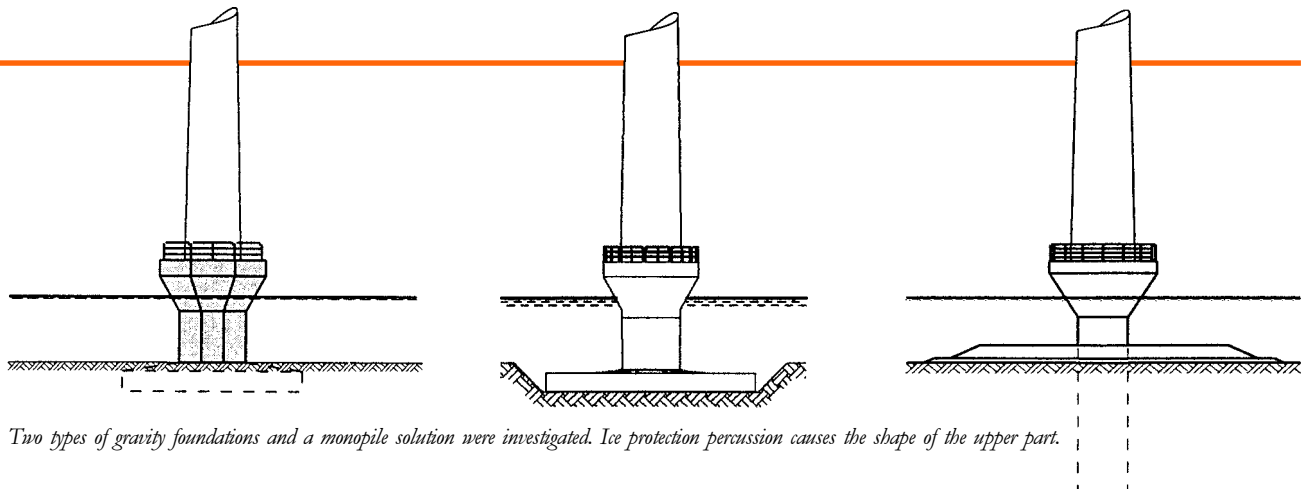

Two types of gravity foundations and a monopile solution were investigated. Ice protection percussion causes the shape of the upper part.

The actual design of the concrete gravity foundation. The height of the total foundation is between 8 and 11.3.

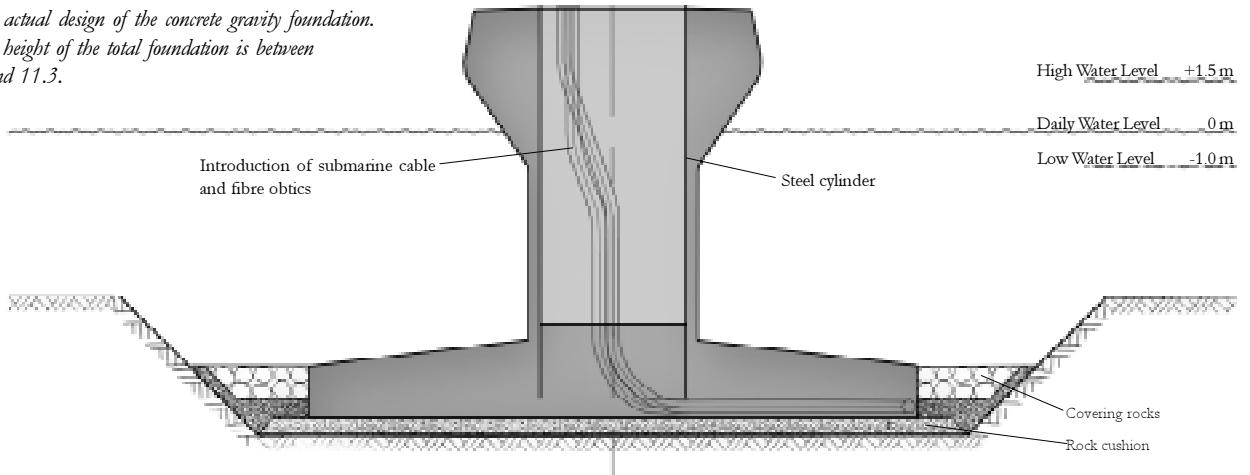

Construction

The well-known contractor Monberg & Thorsen cooperating together with Pihl & Søn won the tender. They built the foundations in the old dry dock of the former B&W Shipyard. Its location nearby Middelgrunden and the ideal working conditions in the dock helped to keep the construction costs low. The lower part of the steel tower together with the transformer, switchgear and control systems were installed on the foundations in the dry dock before floating the foundations to the site. This also helped keeping costs low, as work offshore could be moved onshore.

Simple solutions. Black plastic buckets were used to protect the cable conduits from being blocked by dirt. A hole in the bottom of the bucket allowed the wire for hauling up the cables to pass and at the same time made the buckets unsuitable for other use, so they didn't disappear.

The wires were fastened at the bottom of the foundation and inside the tower, while the foundations still were in the dry dock. After the foundations were placed at the Middelgrunden site, divers attached the cables to the wires at the bottom and the cables were dragged into place.

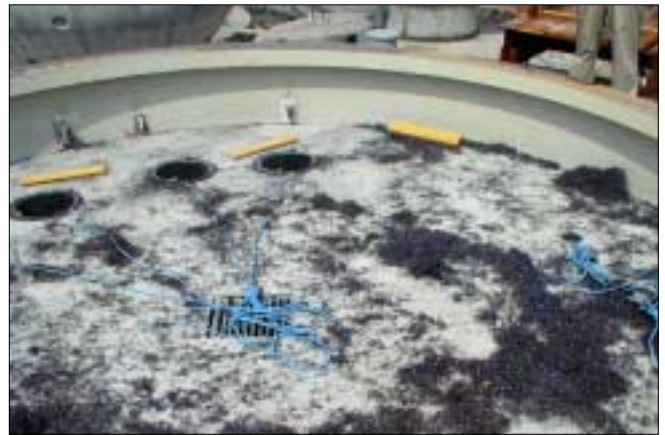

Technical data

Foundation depth.....	4 to 8 metres
Foundation height (total).....	8 to 11.3 metres
Foundation weight (dry).....	1,800 tonnes
Material.....	Reinforced concrete
Shape.....	Circular with ice cone at the upper part



The Wind Turbines

The turbines installed on Middelgrunden are the first 2 MW turbines installed offshore. Turbines larger than 2 MW could have been chosen, but the decision by the developers that the turbines should have at least some months proven track record, limited the maximum size to 2 MW. The turbine manufacturer chosen after the tender was Bonus Energy, who at the time had more than one year of experience with their 2 MW turbine.

Easy maintenance

To avoid high maintenance costs the turbines are constructed in a way that the main components can be changed without using an external crane. A build-in crane in each nacelle can lift the rotor parts and gear, and all parts can be taken down through the tower and out through the double door at the bottom that is designed to allow passage of all parts. It should be noted that for certain operations it is still cheaper to use an external crane.

Limiting visual impact

The turbines are painted in a neutral grey colour (RAL7035) that makes them blend in with the surroundings, thus minimising the visual impact. Each nacelle is marked with a low intensity steady-burn red position light on the top (70 candela). At some point the Danish Civil Aviation Administration demanded that each turbine be marked with a strong blinking light (2000 candela), which would have meant that the conditions in the approval of the project were not fulfilled. For several months this was a case of heavy negotiations, like it has been for other wind developments as well.

For new wind developments stricter requirements demanding stronger light marking and red blade tips can be expected. This will increase the visual impact of offshore wind farms.

The blades are assembled to the rotor at the old quay of the former B&W shipyard and placed on the barge.



October	November	December	January	February	March
Placement of foundations including lower section of tower					
	Placement of upper part of turbine including rotor				
			Production start and test of turbines		

Wind measurements

Meteorological measurements had been collected on a 45-metre mast on Middelgrunden from October 1997 to the end of 1999. The characteristics of these data, including wind speed profiles, turbulence intensity, directional variability and stability, were described.

The average wind speed in 50 metres height is 7.2 m/s corresponding to an energy intensity of 380 W/m². The shadow effect is considerable as expected, when the wind blows directly from north or south, and the annual park efficiency is estimated at 93%.

Production

The turbines are guaranteed to produce 89,000 MWh of electricity during an average wind year. The expected production is 100,000 MWh annually.

From March to December 2001, the first year of operation, the turbines produced 68,000 MWh. This was very satisfactory, since 2001 was the poorest wind year in 22 years with only 80% of the wind in a normal wind year. In 2002 the turbines produced 100,000 MWh with 97% of the wind in a normal wind year. Furthermore there were some halts of operation during the first two years. The turbines have proved efficient in harvesting the wind and the power curve has shown 5.7% better performance than guaranteed. This is following the pattern known from the Lynetten Wind Farm situated at the Copenhagen harbor.

Production figures can be found on www.middelgrund.com. The information is updated every 10 minutes.



Construction

The turbines were manufactured at the Bonus factory in Jutland, Denmark, and delivered to the wharf ready to be shipped out. The construction work was prolonged several months into the winter season due to the delay in seabed preparation. At some point a considerable delay of the whole project was feared. Placement of the wind turbines was very weather dependant. But the work went on day and night and in the end proceeded quite fast with a record of 18 hours for completing two turbines. The first turbine started production at the end of December 2000 and the last - on March 6, 2001. The total delay compared to the original timetable was 2 to 3 months.

The use of a larger floating crane turned out to give opportunity to revise the total installation method in a positive way. The larger capacity allowed the lower tower section including switchgear, transformer and control equipment to be installed in the dry dock. The lower section of the tower already placed on the foundation allowed thereafter an effective way of pulling up the submarine cables into the tower as soon as the foundation was placed on its final site.

Were the lower section of the tower not established in the dry dock, a much larger delay would have appeared.



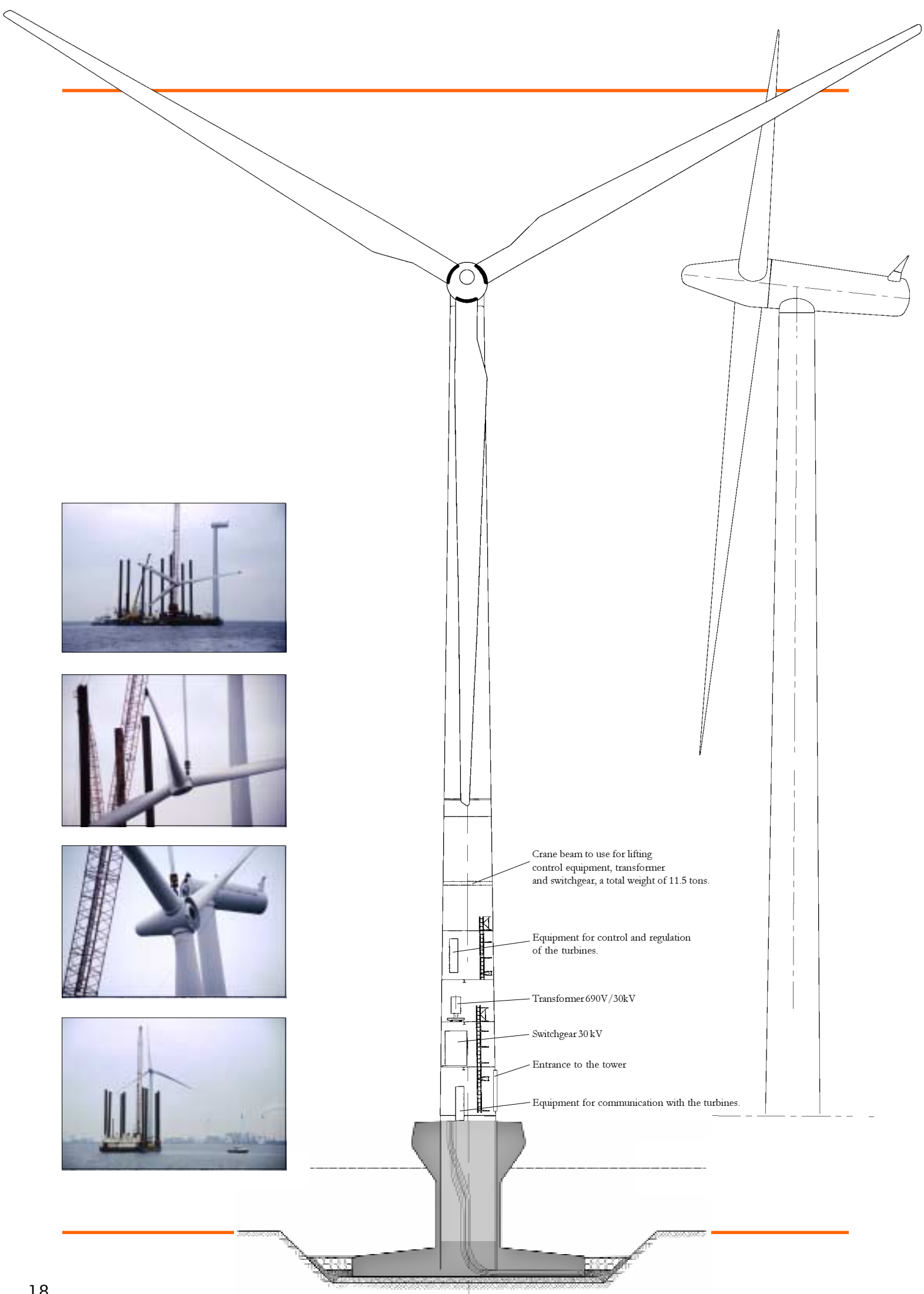

Crane beam to use for lifting control equipment, transformer and switchgear, a total weight of 11.5 tons.

Equipment for control and regulation of the turbines.

Transformer 690V / 30kV

Switchgear 30 kV

Entrance to the tower

Equipment for communication with the turbines.

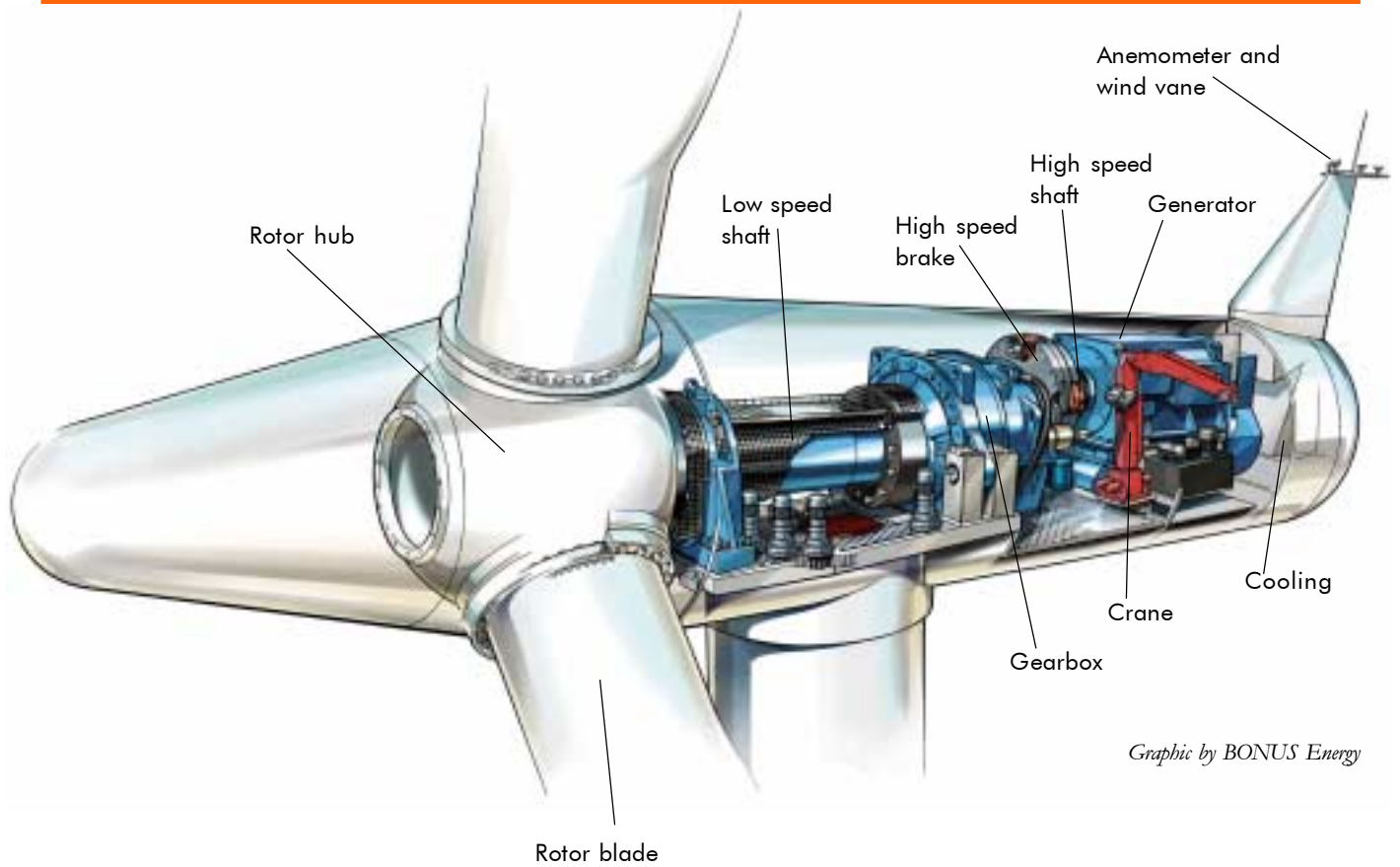

Technical Data

Number of turbines.....	20
Power.....	2 MW/turbine
Hub height.....	64 metres
Rotor diameter.....	76 metres
Total height.....	102 metres
Guaranteed production.....	89 GWh/y
Expected production.....	100 GWh/y
Park efficiency.....	93 %

Wind Parameters at Middelgrunden

Wind speed at 50-m height.....	7.2 m/s
Weibull scale parameter at 50-m height.....	8.1 m/s
Weibull shape parameter at 50-m height.....	2.3
Energy density at 50-m height.....	380 W/m ²
Turbulence intensity at 50-m height.....	0.12

Description based on meteorological measurements by RISØ.

Bonus 2MW Power Curve

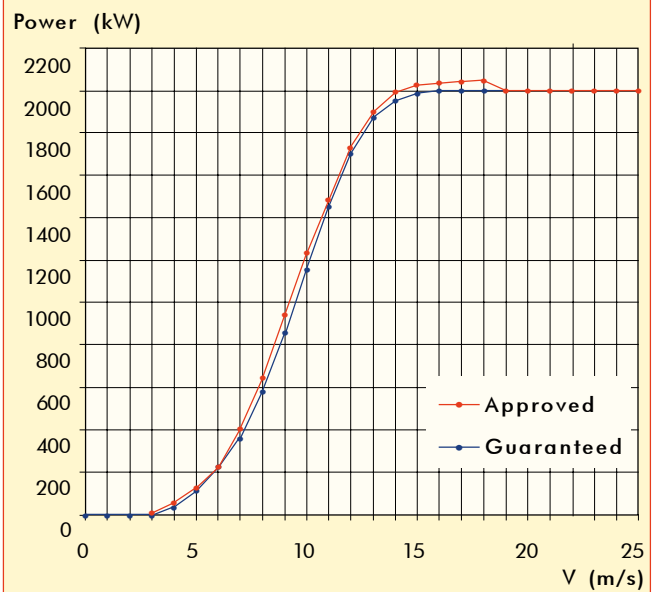

Power curve for the 2 MW turbines based on approved measurements.

May	June	July	August	September
Work on seabed				

Operations at Sea



During part of the work on the seabed all divers from eastern Denmark were busy at Middelgrundten.

The final period of sea operations was prolonged several months into the winter season, which by itself made the work more difficult. The delay was caused by a more difficult than expected seabed preparation, especially the compaction of the rock cushion. Furthermore three accidents with damages of the submarine sea cable happened, and the work at the turbines with the final connection to the grid took longer than expected.

During the contract negotiation and the following period, considerable efforts were put into reducing the period of work at sea and the originally foreseen sequence of operations was changed.

Carefully planning day-by-day was necessary in order to avoid that seabed operations upstream resulted in impossible working conditions downstream caused by particles in the water. Also the weather situation had to be taken into account.

After installation of the turbines up to 38 people coming from different companies were working every day on different turbines. People were often shifting between turbines during the day. To secure the best and safest working conditions, two persons were dedicated only to coordinate these tasks.

Changes

The type and size of the turbine itself influenced the design of the support structure, the construction method and the establishment of the connection to the submarine cables. The parallel decision was necessary because of the tight timetable, but this is not recommendable.

The new sequence of operations demanded a larger barge and crane than originally foreseen in order to enable the transport out of the dry dock. The advantage was that both the lower part of the tower, the transformer and the control equipment could be placed on shore.

The rock cushion is prepared for the foundation.



Placement of submarine cables. The cables are carefully placed on air cushions and floated to the final position. The air is released from the cushions one by one and a diver on the bottom secures the correct position.

Divers

For a long period the bottleneck of the project was the access to divers. Almost all divers available from the eastern part of Denmark were activated during the peak period. They worked with:

- Placing of cables and pulling them up in the tower
- Digging for the foundation and cable trench
- Placing and compacting of rock cushion
- Levelling compacted rock cushion
- Placing foundation caisson
- Removing block for lifting operations

Grid connection

The wind farm is connected from its centre to the shore with two 20 MVA cables placed at a distance of 15 metres. They are operated as a single unit. The distance to the 30/132/400 kV transformer at the Amager Power Plant on the shore is 3.5 km. The turbines are connected using 20MVA cables.

In each wind turbine there is a transformer installed on the bottom of the tower. It is a 30 kV dry transformer produced by Siemens. The transformers have been very problematic and several burnt out during the first year of operation (more details on page 22).

October	November	December	January	February
	Placement of foundations including lower section of tower			
	Placement of sea cables between turbines			
	Placement of upper part of turbine			
			Establishment of erosion protection	

Technical Data

Switchgear	30kV
Transformer	690V/30 kV dry transformer
Cables	20 MVA, three-core XLPE submarine cables

Cables

The placement of the submarine cables was carried out without any difficulties using a specially built vessel from NKT Cables. The relatively shallow water and good weather conditions contributed to that.

Separating the marine reinforcement from the core of the stiff cables within the tower turned out to be much more complicated than expected because of the narrow space.

The contractors working with the establishment of erosion protection damaged the cables three times even though it was a simple sea operations of a well-proven type. Luckily two spare cables had been produced so the delay due to the damages of cables was minimised.

Final establishment of power connection

The final check of switchgears and grid connection turned out to be more time consuming than anticipated. One reason could be the successive starting up of the turbines, which called for several 24 hours periods of test for grid and power stability.

The successive starting up also gave unexpected problems, as the power backup for the switchgears was not foreseen to be larger than during normal operations.

On Tuesday December 5, the last foundation was placed on its rock cushion without troubles. A crane floated the foundations including the lower part of the tower from the dry dock to the site.



3 alternative solutions for grid connection

1: Star connection – each turbine is directly connected to the power plant. This solution is very flexible and stable but very expensive. At the early stages the utilities demanded a star connection, which in reality would have stopped the project. After a lot of political work the demand was dropped.

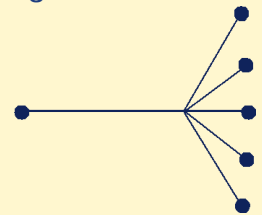

2: Ring connection – Each of the two turbines at the end are connected to the power plant by a 20 MVA cable. This solution is quite stable. If the cable between two turbines breaks down, all turbines can still transfer electricity to the grid. Depending on where the breakdown is, the capacity will be limited for some of the turbines.

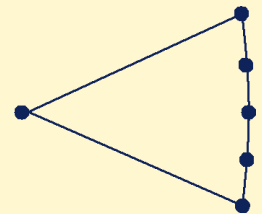

3: Central connection – The central turbine is connected by two 20 MVA cables to the power plant. The other turbines are connected to the central turbine in series connection.

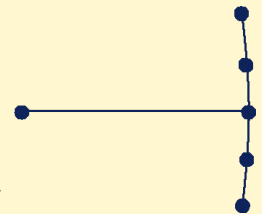

This solution is the least flexible. If the cable between two turbines breaks down, some turbines will be cut off from the main cable. The third solution was chosen, as the estimated production loss in the last solution was smaller than the extra costs for establishing two separate cables.

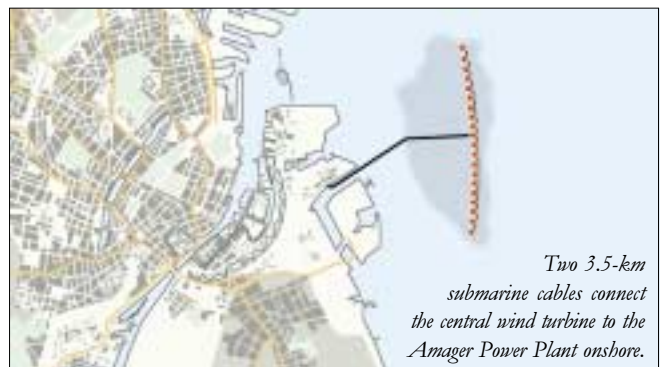

Two 3.5-km submarine cables connect the central wind turbine to the Amager Power Plant onshore.

Operation

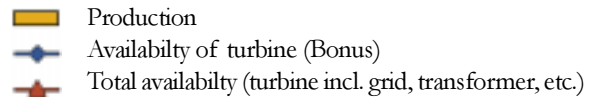

Production and availability May 2001 - December 2002

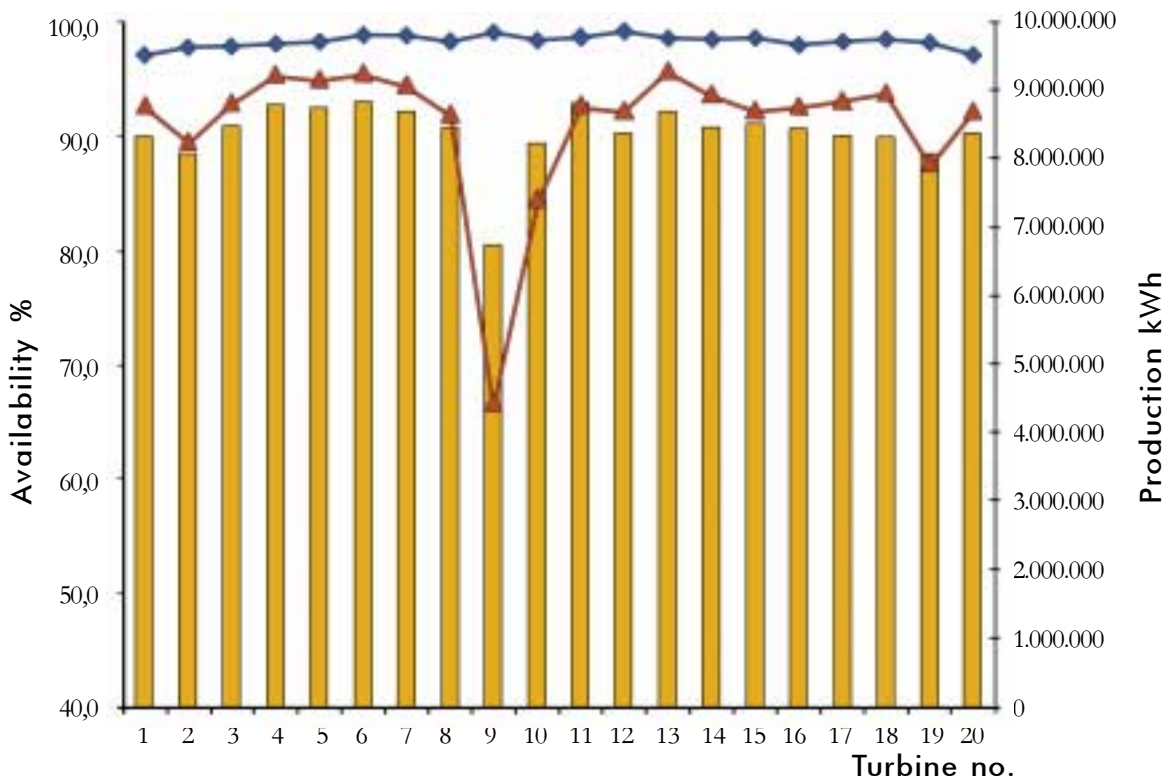

The turbines' production has been satisfactory during the first two years of operation. The output was higher than budgeted, even though there have been several halts in production. The main problem has been transformer damages, which is still being investigated. After the first two years it can be concluded that the efficiency of the turbines is high.

Production

The Cooperative's ten turbines produced 50,659 MWh in 2002, which was 18.4% above budget. 2002 was an ordinary wind year. The wind output in northeast Zealand was 97% of a normal year. In 2001 the turbines produced more than budgeted, when taking into account that 2001 was a very poor wind year.

Availability

The availability tells how often the turbines operate flawlessly. In 2002 the availability for all turbines was between 97.6% and 99.3% with an average of 98.7%. This is better than in 2001, the first year of operation, with an average availability of 97.3%. The total availability includes areas outside the turbine such as flaws in the electricity net, transformers etc. The total availability in 2002 was on average 94.1% for the entire park, which is an improvement from the first year's 85.4%.

Initial problems

Next to the problems with the transformers other difficulties and halts occurred during the first period of operation. Three

switchgears were leaking SF6 gas and had to be repaired. Bonus had to stop the turbines to finalise the installation. Further on the turbines' output was limited for a period due to diggings around the main cables connecting the turbines to the shore. When working on one cable, the other cable was in operation and able to transfer 20 MW corresponding to half capacity. The total loss of operations the first year was approximately 10%, mainly due to the failures in transformers. Only a smaller part of the losses was covered by the insurance, due to 7 waiting days during summer and 12 waiting days during winter.

Transformer damages

Problems with the switchgear and the transformers have been the main issue from the very beginning. In December 2002 the 9th transformer short-circuited. Six of the damaged transformers belong to Copenhagen Energy Wind and the last three to the Cooperative.

One breakdown was caused by a misplaced phial. So far it has not been possible to explain the other breakdowns. A task force has been formed with the participation of experts from all the involved parties. The group has commenced a measurement program in January 2003 to find the technical cause of the breakdowns. The result is expected by the end of March, 2003.

The breakdowns have financial and probably legal consequences. With reference to the contract with suppliers the transformers are still covered by the guarantee period. From the owner's point of view the supplier was always aware of the usage and load of



the transformers. Hence they maintain that the supplier is responsible for the transformer breakdowns until otherwise is proven.

The short circuit of the transformers has also drawn media attention to the wind farm. At some point the headline in media was „fire at Middelgrunden“. But the chairman of the Cooperative could assure the journalists that no transformers had „burnt down“, they had „burnt out“!

Daily operations

The Middelgrunden Wind Turbine Cooperative and Copenhagen Energy Wind cooperate on the operation of the wind farm. An organisation diagram can be found on page 9. Bonus has the main responsibility for the turbines. It monitors the turbines 24 hours a day and is obliged to take action within 3 hours during daytime to keep the turbines running. The monitoring system will be upgraded in 2003, so an e-mail is sent to the monitoring centre in case of errors. The original monitoring system at Bonus is not online, but done through a call to the turbines every 3 hours. The new e-mail system will give the operators a faster update, and that will result in faster response to faults in the turbines.

Another part of the operations is the grid connection of the turbines. CE Partner (a division of Copenhagen Energy) is responsible for these high voltage systems. The Cooperative's secretariat is in daily contact with both Bonus and CE Partner and handles operational conditions, which aren't related to these areas, e.g. inspection of the foundation or similar tasks.

Bonus delivers a monthly detailed report on operations and an overview of the turbine stops. Therefore the management has an excellent overview of the operations and the secretariat has good tools to follow up on possible problems. In 2002 Bonus has done a series of modifications in the turbines besides the usual service. For example, the replacement of the generator cables started in 2002 and will continue in 2003.

Information on operation is frequently updated on the web page www.middelgrunden.dk

Maintenance

Below some examples of incidents and circumstances are listed that have caused a halt in operation, as well as examples of maintenance.

- The anemometer and wind vane were covered by ice. Bonus de-iced the turbines by heating the anemometer and wind vane through remote control.
- Due to the risk of transformer short-circuits, the operations manager of CE Partner decided that smoke masks were obligatory when working inside a turbine and workers were not allowed to pass the transformer when voltage was on in the system. This led to a large amount of disconnections and the procedure has been changed in the beginning of 2003.
- The foundation rails had cracked in several places. It was observed that some of the rails' horizontal pipes vibrated during strong wind. Supports have been installed to prevent the vibrations.
- The life saving equipment is reinstalled on three turbines after it was lost.
- Due to problems with the warning lights on top of the turbines, they have been changed to a better and less energy-consuming model.
- Faults in the power system at Lynetten Sewage Plant shut down the entire wind farm for 12 hours. Lynetten is correcting the system and future problems should be avoided.
- The generator cables in the nacelle have reached too high temperatures, because the cables have been packed too tightly. The high temperature and mechanical stress have damaged the cable encapsulation. Hence, Bonus decided to change all cables.



Investment Budget

Investment budget and final accounts Middelgrunden Wind Turbine Cooperative (10 out of 20 turbines)	Final Account December 31, 2002 mill. EUR	Budget mill. EUR
Wind turbines	13.3	13.4
Foundations including changes after the tender to reduce the time spent on offshore operations	6.5	5.0
Grid connection, from land to farm	not included	not included
Grid connection, offshore	2.2	2.3
Design, advice and planning	1.5	1.1
Establishment of wind turbine cooperative	0.8	0.5
Other costs	0.3	0.8
Compensation for southern turbines	-0.3	
Total	24	23

The investment for the wind turbine cooperative ended up being a little larger than originally budgeted. Copenhagen Energy (CE) paid 335,000 EUR in compensation to the cooperative, because the estimated production is a little lower for the southern turbines owned by the cooperative than for the northern turbines that belong to CE. The grid connection from the wind farm to land was paid by CE.

Originally the total investment budget of the Middelgrunden Offshore Wind Farm was 46 million euro. The signed contracts were cheaper than the budget, and for a long time we actually expected the final investment to be lower than budgeted. But extra costs were added during the construction and the total investment ended up at about 48 million euro, not including costs for establishing the cooperative and administration costs of Copenhagen Energy.

The actual building costs had been approximately 5% more expensive than budgeted. This was mainly due to more expensive foundations than the budget in the signed contract. The case was submitted for arbitration and was only closed late 2002.

Settling the final payment for foundations

The two companies constructing the foundations claimed extra expenses of 4.1 million euro, which they demanded the developers to pay. When the cooperative and the utility disagreed on the extra expenses and denied to pay, the case went to the Court of Arbitration.

Only 2 years after the construction work ended, the parties reached a settlement, and the court case was called off. According to the settlement the developers had to pay 0.87 million euro each plus another 0.17 million euro in interest costs. The settlement was reached after independent expert evaluation of the claims followed by a dialogue between the parties.

The claims were mainly connected to extra work with digging of placement holes and establishment and compaction of rock cushions for the foundations. The case shows the importance of well-prepared contracts.

Sale of shares

The cooperative's ten 2 MW turbines were sold in 40,500 shares, each representing an annual production of 1,000 kWh. The total investment budget of the cooperative was 23 million euro and each share was offered at 570 euro. The number of shares offered was decided as based upon 90% of the guaranteed production.

All shares had to be paid up front in order to follow the constitution of the cooperative, according to which the cooperative could not contract debt.

The cooperative had organised attractive loan offers with two different banks. But less than 5% of the shareholders made use of this opportunity. The only security demanded by the banks was the project itself and income from electricity production. The loans were offered with a variable interest rate of 7.40-7.45%, a term of 10 – 15 years and a small fee of 40 euro per loan.

Pre-subscriptions

In the early stages before permissions were obtained and the project became a reality, the wind cooperative financed its work by selling pre-subscriptions. Each pre-subscription cost 7 euro and was a reservation of one share. 10,000 people joined the cooperative and bought nearly 30,000 pre-subscriptions during the planning phase. All these people risking a smaller amount of money each were important for the realisation of the project. When investing in shares the value of the pre-subscriptions was subtracted from the price of the first share the members bought.

Working Expenses and Profit

Based on the original budget the annual profit would be 70 euro per share during the first 6 years of operation and lower in the following years due to a lower selling price of electricity. According to budget the simple payback time of the investment is 8 years and the return rate is 7.5% after depreciation.

The first 2 years of operation have shown a higher production and the new estimation of the annual production is 1200 kWh per share. But in the same period extra costs have occurred due to the higher investment and the transformer short circuits (see page 22). All in all the profit has been as budgeted so far, and higher profits can be expected in the coming years, where the costs will be lower.

Renewable Energy Scheme

The Danish Renewable Energy Scheme has changed a lot the last years. Middelgrunden is covered by an interim scheme and the income from electricity sale consists of a price for the electricity, which is fixed for the first 10 years, and a premium for renewable energy, which is fixed for the first 5 years (12,000 full-load hours). In 2000 the Danish government prepared a new Renewable Energy Scheme based on the sale of green-label certificates. This scheme has been postponed until the EU-market for green-label certificates is introduced. The plan is to issue green-label certificates that are sold on the free market. All consumers will be obliged to buy a certain amount of their electricity as green-labelled electricity.

Instead a new scheme was introduced on January 1, 2003. The conditions are not totally determined yet. So far they look less favourable for new developments as well as for old turbines outside the period with a fixed price. Still a lot of new turbines were installed onshore in 2002, because a special premium was paid for replacement of old turbines with new capacity. The aim is to replace small old turbines with fewer large turbines. The premium is paid for 3 times the capacity for turbines smaller than 100 kW and twice the capacity for 100-150 kW turbines.

Taxation

Annual income less than 400 euro from sale of electricity is exempted from tax for private people. This corresponds to the budgeted income from 5 shares. If the income is higher than 400 euro, then 40% of the income above 400 euro is still tax-free. For shareholders with more than 5 shares it is also possible to pay tax of the capital yield.

Key Figures

Investment	47.6 mill. EUR
Annual production	100,000,000 kWh
Investment/kW	1.2 EUR/kW
Production price of electricity	0.044 EUR/kWh

Calculation rate = 5%, lifetime = 25 years, service costs = 0,01 EUR/kWh.

Sales price of electricity delivered to the grid

Year	Electricity	Added price for renewable energy
	EUR/kWh	EUR/kWh
0-5	0.044	0.036
5-10	0.044	0.013 - 0.036
10-25	Market price	Green label certificate to be traded (planned)

The added price for renewable energy is fixed at the moment and will remain fixed until a EU market for green label certificates has been established. In future the certificates will be sold on the free market, and all consumers will have to buy a certain amount of their electricity as green-labelled electricity. For the Middelgrunden project the added price for renewable energy is fixed at 0.036 EUR/kWh for the first 12,000 full-load hours (approximately 5 years production).

Shareholder Economy - budget for one share, year 1-6

Investment	570 EUR
Annual production	1000 kWh
Selling price of electricity	44 EUR
Added price, RE	36 EUR
Income/yr	80 EUR
Maintenance cost	-10 EUR
Net income/yr	70 EUR
Rate of return	12.5%
Simple pay-back time	8 years
Annual depreciation	5%
Depreciation	28.5 EUR/year
Income after depreciation	42.5 EUR/year
Rate of return after depreciation	7.5%

This is the original budget from the project prospectus. In reality both investment and production are higher than budgeted and the economy is foreseen to be better. Income from wind shares below 400 EUR/year is exempted from tax, which is why many shareholders invested in 5 shares.



Literature

- *Local Investment into Renewable Energy, Collection of European Experiences in Local Investment*
J.H. Larsen, et al. PREDAC – WP1, supported by the EU Energie programme, 2003.
- *Middelgrunden Offshore, The Project*
Bonus Energy A/S, Brande, 40 pp., 2001.
- *Middelgrunden 40 MW Offshore Wind Farm, a pre-study for the Danish offshore 750 MW wind programme*
H.C. Sørensen et al. Proceedings ISOPE 2000 Conference Seattle I, 484-491, 2000.
- *Havmøller på Middelgrunden, Forundersøgelser, fase 2 og 3 (Offshore Turbines at Middelgrunden, pre-investigations, phase 2 and 3)*
J.H. Larsen, H.C. Sørensen, et al. Copenhagen Environment and Energy Office, 2000.
- *VVM redegørelse for vindmøllepark på Middelgrunden (Environmental Impact Assessment of the Wind Farm at Middelgrunden)*
J.H. Larsen, H.C. Sørensen et al. Copenhagen Energy and Middelgrunden Wind Turbine Cooperative, Copenhagen, 60 pp. (in Danish with English summary), 1999.
- *The Wind resource at Middelgrunden*
R.J. Barthelmie, Risø National Laboratory, 46 pp., 1999.
- *Vindmøllepark på Middelgrunden II - Æstetisk vurdering og visualisering (Wind Farm at Middelgrunden II - Aesthetic Estimation and Visualization)*, Møller & Grønberg - Århus (in Danish), 1998.
- *Vindmøllepark på Middelgrunden - Æstetisk vurdering og visualisering (Wind Park at Middelgrunden - Aesthetic Estimation and Visualization)*
Møller & Grønberg & Rambøll - Århus (in Danish), 1997.
- *Action Plan for the Offshore Wind Farms in Danish Waters*
The Offshore Wind Farm Working Group of the Danish Utilities and the Danish Energy Agency, SEAS Haslev, 44 pp., 1997.

Related Web Pages

Danish Wind Industry Association	www.windpower.dk
Danish Turbine Owners Association	www.dkvind.dk
Danish Energy Authority	www.ens.dk
PREDAC	www.cler.org/predac/
The EU Concerted Action	www.offshorewindenergy.org
Wind Force 12	www.vea.org/src/information.htm
Energi- & Miljødata (EMD)	www.emd.dk
Samsø Offshore Wind Farm	www.samsøhavvind.dk
Horns Rev Offshore Wind Farm	www.hornsrev.dk
Nysted Offshore Wind Farm	www.nystedhavmoellepark.dk



The Middelgrunden wind farm is developed in collaboration between Middelgrunden Wind Turbine Cooperative and Copenhagen Energy Wind.

Owner 10 turbines north
Copenhagen Energy Wind
www.ke.dk

Owner 10 turbines south
Middelgrunden Cooperative
www.middelgrunden.dk

The cooperative can be contacted through the secretariat, CEEO, or by e-mail: lauget@middelgrunden.dk



www.middelgrunden.dk

At the webpage you can find more information about the project, see online production data, order photos, tours etc.

Visit the windfarm

CEEO organises presentations about and tours to the Middelgrunden Wind Farm.
See www.middelgrunden.dk or contact CEEO.

Acknowledgment

The extensive pre-study of the Middelgrunden project and the production of this booklet was made possible by support from the Danish Energy Authority.

Project Management

Total project	SEAS Wind Energy Centre	www.seas.dk
The Cooperative	CEEO	www.kmek.dk
	SPOK ApS	www.spok.dk

Contractors

Turbines	Bonus Energy A/S	www.bonus.dk
Foundations	Monberg & Thorsen A/S	www.monthor.dk
	E. Pihl & Søn A/S	www.pihl-as.dk
Submarine Cable	NKT Cables A/S	www.nkt-cables.com
Switchgear, Transformer	Siemens A/S	www.siemens.dk

Technical Consultants

Foundation Design	Carl Bro as	www.carlbro.dk
Design, Park Layout	Møller & Grønberg	www.mgarkitekter.dk
	Rambøll	www.ramboll.dk
Sea Bed Study	GEO	www.geoteknisk.dk
Water Flow Study	LIC engineering A/S	
Wind Analysis	Risø National Laboratory	www.risoe.dk

Published by

Copenhagen Environment and Energy Office CEEO
Blegdamsvej 4B
DK-2200 Copenhagen N
Ph: +45 – 35 37 36 36
Fax: +45 – 35 37 36 76
kmek@kmek.dk
www.kmek.dk

CEEO is a local association that provides free, impartial information and guidance on environment-friendly and resource saving solutions. Since 1987, CEEO has initiated energy and environment activities and urban ecology projects in Greater Copenhagen.

Text

Ann Vikkelso (ed.)
Jens H M Larsen
Hans Chr. Sørensen

Language Advice

Liliya Izmodenova

Design & Layout

Mads Eskesen

Photo

Mads Eskesen - www.earth-vision.biz
Jens H M Larsen - p. 8, 11, 28
Hans Chr. Sørensen - p. 15
Søren Hermansen - p. 5
Søren Nielsen - p. 8
Møller & Grønberg - p. 10, 11
Adam Schmedes - p. 11
Hedeselskabet - p. 12

Supported by

The Danish Energy Authority
Middelgrunden Wind Turbine Cooperative

Printed on cyclus print by
Combi Print, Copenhagen

Copenhagen, March 2003

ISBN 87-986690-3-6



The Middelgrunden Offshore Wind Farm is a unique story of how 5 years of work of concerned citizens has resulted in the world's largest cooperatively owned wind development.

Today the 20 turbines owned by Middelgrunden Wind Turbine Cooperative and Copenhagen Energy are spinning just outside the Copenhagen Harbour. The wind farm provides 4% of the electricity for the city and adds a new landmark to Copenhagen.

This brochure summarizes the experiences from the project to support other local initiatives around the world.



Some of the 8500 members of Middelgrunden Wind Turbine Cooperative visiting the offshore wind farm.